



Carbon dioxide (CO₂) Emission Reduction from Automobiles and Industries Using Algae

SHAIL DESAI^{1,*} VRAJ PATEL^{1,*} HIMANSHI SHAH¹

¹Department of Chemical Engineering, School of Engineering and Applied Science, Ahmedabad University, Navrangpura, Ahmedabad 380008, Gujarat, India

Abstract:

As it is known the quantity of vehicles are expanding at a quick rate subsequently causing considerable increase in environmental pollution which should be controlled. Environmental pollution control utilizing microbiology is consequently an energizing zone of science and innovation which can be utilized for controlling pollution level, accordingly we have utilized green algae to diminish the measure of carbon compound in the exhaust gases of vehicles and industrial flue gases by development of oxygen using of green algae in presence of water, sunlight or a light source and little amount of acetic acid. In an exhaust pipe there is sulphur dioxide and nitrogen oxide in deplete, which would ferment the water if discharged directly into the algae chamber and thus for that a membrane chamber was introduced to strip down the CO₂ gas and pass it directly into the algae chamber without any other acidic gases. Green algae does not do well with higher concentration of acetic acid in this way concentration of acetic acid was kept as low as possible keeping in mind the end goal to influence green algae to photosynthesize within the sunlight source in this way reducing carbon compound levels from the flue gases and discharging oxygen along with giving biomass from which food ingredients, bio-diesel and other products as a result.

1. Introduction

Pollution is the biggest challenge of humanity and out of that the major pollutions are Air, water and land pollution. Emission of CO₂ directly into environment is very dangerous and is responsible for change in net flux of radiant energy between different layers of atmosphere and so global

warming could become an important global environmental problem during the 21st century. Various resources both natural and man-made are responsible for CO₂ emission. Many researchers suggest and industries implement to establish an effluent water treatment plant but these plants emit major amount of greenhouse gases an alternative to these problem is to make basic biofuel but it is also not stable. To overcome these problems one of the many biological ways of algal growth to absorb the CO₂ from flue gases of industries and commercial vehicles is explored in this paper.

In CO₂ fixation by algae sunlight is being used to convert CO₂ to carbon. Catching CO₂ from vent gases is the primary rule which needs preventive activity, at both national and worldwide levels to limit this potential activity. These technologies of enhanced biological carbon fixation might assist in safeguarding the environment. The catching of industrial and commercial CO₂, reusing it and changing over it into valuable assets with the assistance of reasonable means would be exceptionally exciting.

Catching of CO₂ is a technique for ozone depleting substance relief by algal development. Miniaturized scale algal growth can settle CO₂ from three diverse sources, CO₂ from the atmosphere, CO₂ in release gases from industries, and CO₂ from dissolvable carbonates out of which we will be focusing on the latter two because to trap CO₂ from atmosphere with further treatment along with transportation and storage is expensive and mammoth size task. In this paper, two major problems of CO₂ emission i.e. CO₂ emission from industrial flue gases and

CO₂ from exhaust systems of vehicles has been taken into account and a considerable solution for both of them has been given. Firstly for industrial flue gas emission, ways to strip CO₂ gas from the flue gas and ways to store CO₂ and treat it to a certain decent efficiency has been given which will be explained in detail in further part. Secondly for automobiles a new design with algae infused inside the muffler of the exhaust system is given in which the CO₂ is trapped along with other harmful carcinogens like carbon-monoxide and sulphur components which intern will help in reducing the CO₂ emission from the automobiles, the design will be explained in the later part of the paper with details.

2. What are algae?

4 billion years ago there was no life on earth because of no oxygen and the surface of the earth was too hot. The atmosphere of earth was only composed of hazardous and heat confining gases like CO₂ and CH₄ gas. Fossil records demonstrate that a little plant emerged and used the sun's energy and for chemical reaction of photosynthesis process, to separate a CO₂ particle and discharge the O₂ atom in the environment. Algae are composed of oils, sugars, carbohydrates and proteins, which can be used to reuse greenhouse gas emissions and treat wastewater. Countries across the world are continuously trying to reduce CO₂ discharge to meet the energy demands. The algae production to some degree may furnish a chance to manage both the issues.



An important characteristic of algae is its capacity to utilize sunlight and the CO₂ in the air to create their own particular complex supplements. This procedure, called photosynthesis, takes place in chloroplasts, cellular parts that contain the vital enzyme machinery to transform solar energy into

chemical energy. Each plant cell can have 20 to 100 chloroplasts.

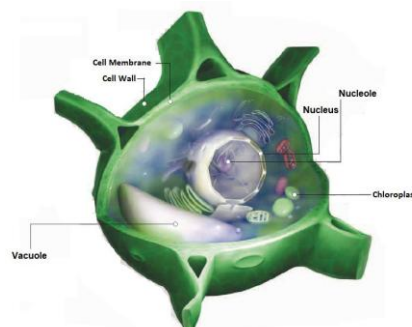

Green algae upgraded with chloroplasts which allows photosynthesis readily and significantly increases O₂ accessibility. Life is influenced from light as electrons pass from the radiant energy of the sun and algae uses the electromagnetic radiation, photons, to split CO₂ and H₂O molecules.

Algae combine hydrogen with carbon to make plant bonds with high-energy hydrocarbon and release oxygen into the atmosphere. Microalgae can fix CO₂ utilizing solar energy with efficiency 10 times more prominent than other plants. While normal land plants can produce protein in 150 days, algae culture produces protein daily and continuously required that the sun shines and the culture has sufficient nutrients.

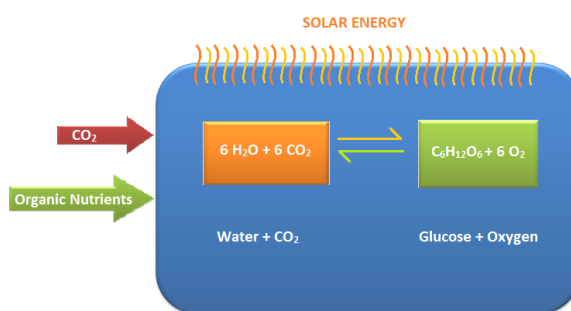

Algal biomass is made up of simple plant sugars that is glucose and sucrose, minerals and nutrients from the surrounding water and produces plant biomass consisting of different types of proteins, carbohydrates and lipids. Along with this, the process discharges extensive pure O₂ to the atmosphere.

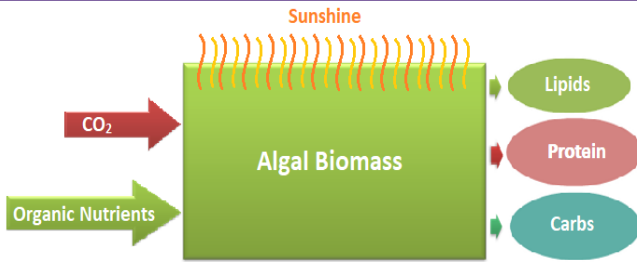

neutralized namely carbon monoxide (CO, poisonous gas), nitrogen oxides (cause of acid rain and smog) and hydrocarbons (cause of smog). Carbon monoxide is converted into carbon dioxide which increases the amount of carbon dioxide as the completely burnt fuel also gives carbon dioxide.

Major reasons for CO₂ emission are:

- Cement factories
- Vehicle emissions
- Power plants and industries
- Breweries and large users of natural gas such as restaurants.

New methods for CO₂ capture will be helpful. For example, cars produce around 300 grams of CO₂ for every kilometre. If a carbon capture filter is designed for vehicle exhaust pipes, there will be a boundless supply of low-cost CO₂ for growing algae. The CO₂ filters could be recycled at service stations and used to feed solar gardens and nurseries.

The carbon dioxide from these vehicles is responsible for the greenhouse effect which in turn is responsible for global warming. This greenhouse gases traps the heat to the surface of the earth which increases the temperature of the earth considerably and does not allow it to cool down.

For this purpose if below shown in figure design modifications of muffler are done with integration of algae chamber into it, the CO₂ emission can be brought down considerably but we have to control the algal growth because if it starts growing beyond certain limits it might choke the exhaust system which will affect the engine efficiency and performance.

3. Use in automobile

Exhaust gases come out of the manifold of the engine into the mid pipe to catalytic converter where three major harmful compounds are

The below shown figure suggests the plausible design modifications in the exhaust system of the cars to introduce algae in to the system. The square box shows the added part into the system.

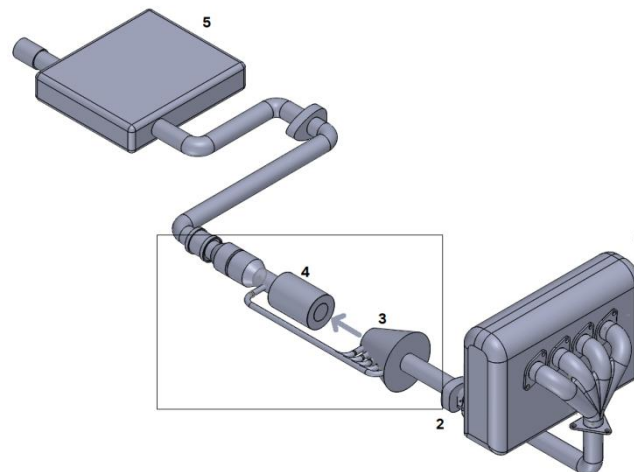

Design Specifications:

1. Exhaust gases coming out of the engine manifold goes into catalytic converter.
2. The catalytic converter passes the gas into 3. (membrane chamber).
3. In membrane chamber the CO₂ gas is absorbed and passed to 4. (algae chamber), the stripped of gases like nitrogen oxides etc. are forwarded to the muffler bypassing the algae chamber as these gases are acidic for the algal growth.

4. In algae chamber the CO₂ is used by the present algae and the rest of the CO₂ and O₂ produced is passed through the muffler into the atmosphere.

The gases out of manifold after being catalytically converted are passed through a membrane chamber made of PVDF hollow fibre membrane which absorbs the CO₂ and passes other gases to the exhaust pipes attached right below the chamber. The absorbed CO₂ is then passed to the algae box containing a mixture of green chlorella algae, water and small amounts of acetic acid (CH₃COOH) to neutralize the effects of any SO₂ from the exhaust pipes which help to protect algae from harmful acids and grow further, when exhaust passes through this chamber the algae undergoes the process of photosynthesis in the presence of light source in order to decrease the carbon content of the exhaust and increase the amount of oxygen levels and finally releasing into the atmosphere thus enhancing the quality of exhaust which is released into the atmosphere. The pipes from the algae chamber and membrane chamber are different in order to protect the generated oxygen from reacting with any of the other flue gases. But at some point the maintenance cost for membrane and algae storage tank gets higher. So to get rid of this problem instead of using membrane and algae storage tank the emitted gases from vehicle can be stored to a small gas storage tank and then the stored gas is transferred to the Algae green gardens (algae manufacturers).

4. Algae Green Gardens

Algae green garden is the concept of algae manufacturing plant using CO₂ and sunlight. Once the emitted gases from vehicle are transferred to the plant, the gases will undergo the CO₂ separation treatment and the separated CO₂ will get injected to algae reactor. Algae reactors are one type of storage tanks which contains algae, water, salt and chemicals required to increase the sustainability and absorptivity of algae. Algae reactors can be tubular or rectangular made of transparent materials or open pond so that the

algae can easily get the sunlight required for the photosynthesis process. In case of plants economy vehicles can't provide the large amount of CO₂. To solve this problem manufacturer can use the alternative sources for CO₂ for example making cement releases a lot of CO₂. Four trillion kg of cement are created globally each year, spewing about two trillion kg of CO₂ into the atmosphere. Instead of releasing these much of CO₂ it can be used as feed for algae green gardens. Also from the various metal industries CO₂ can be collected and used as a feed. The produced O₂ from algae garden can be used for medical treatments, welding and Scuba tank etc. The algal biomass which is contains high protein and carbohydrates have many applications like: Algae can be used to feed animals that deliver high caloric meat like fish, fowl etc. Grasslands and forests can be saved by feeding grazing animals with algae which can be replanted with vegetables and nuts that are rich in calories. Organic material required to enrich the soil can also be obtained from algae along with nitrogen stacked organic manure that supports nuts, vegetables and other high caloric food crop.

5. Conclusion

It has been observed that present emission levels of CO₂ and other greenhouse gases is increasing rapidly and it is very necessary for controlling these pollutants, thus algae can be efficiently used to decrease the levels of carbon compounds presents in the exhausts of automobiles as well as industries using simple but cost effective methods, but the algae has to be protected with the help of acetic acid so that its grows further and photosynthesis goes on without any acidic effects. Also algae gives a certain amount of food ingredients, bio-diesel etc. from the biomass produced along with O₂ which is beneficial for the society. This system is quite cost effective and possible in near future and will help to reduce the greenhouse effect up to quite an extent.



References

- [1] S.P. Singh, Priyanka Singh, Effect of CO₂ concentration on algal growth : A review, *Renewable and Sustainable Energy Reviews* 38 (2014) 172–179
- [2] Fabián Cassan, *PLANTS, ALGAE AND FUNGI*, Britannica Illustrated Science Library, Encyclopaedia Britannica, Inc. Editorial Sol 90, 2008.
- [3] Mark Edwards, Green Solar Gardens-Algae's Promise to End Hunger, www.GreenIndependence.org, 2008
- [4] Eiichi Ono, Joel L. Cuello, Selection of optimal microalgae species for CO₂ sequestration, Department of agriculture and biosystems engineering, The university of Arizona.
- [5] Swamini Chopra, Pooja Achari, Vaishali Kulkarni, Current market technology used to reduce CO₂ emissions from diesel engines. *International journal of scientific engineering and applied science (IJSEAS)*, volume 2, issue 12, 2016.
- [6] Xunmin Ou, Xiaoyu Yan, Xu Zhang and Xiliang Zhang, Life-Cycle energy use and greenhouse gas emissions analysis for bio-liquid jet fuel from open pond-based micro-algae under china conditions, *Energies* 2013.
- [7] Reducing CO₂ emissions from cars, German advisory council on the environment SRU, 2005.
- [8] Vicente Diaz, Susana Sanz, Reduction of CO₂ emissions in the automobile industry, University of Madrid, 2009.
- [9] P. Sriraman, R. Balasubramani, V. Dhinesh, S. Dhinesh, R. Harnish, Study on exhaust emission and its reduction techniques in automotive engines, *International journal of advanced scientific and technical research*, Issue 5 volume 7, 2015.
- [10] James V. Moroney and Aravind Somanchi, How do algae concentrate CO₂ to increase the efficiency of photosynthetic carbon fixation?, *Plant Physiology*, January 1999, Vol. 119, pp. 9–16, www.plantphysiol.org © 1999 American Society of Plant Physiologists.
- [11] Stephen Bleakly and Maria Hayes, Algal Proteins: Extraction, application and challenges concerning production, *Foods* 2017, 6, 33; doi:10.3390/foods6050033
- [12] Rahul Ganji and VN Yenugula, Emission reduction in automobile engine exhaust using biocatalytic converter: An Experimental Study, *IOSR Journal of Mechanical and Civil Engineering (IOSR-JMCE)* e-ISSN: 2278-1684, p-ISSN: 2320-334X, Volume 14, Issue 6 Ver. II (Nov. - Dec. 2017), PP 24-28, www.iosrjournals.org
- [13] Use of algae and aquatic macrophytes as feed in small-scale aquaculture – A review
- [14] Aparna Vidyasagar, What are Algae?, *Live science contributor*
- [15] Martin A. Elliott, Gerge J. Nebel & Fred G. Rounds (1955) The Composition of Exhaust Gases from Diesel, Gasoline and Propane Powered Motor Coaches, *Journal of the Air Pollution Control Association*, 5:2, 103-108, DOI: 10.1080/00966665.1955.10467686
- [16] Luv Nagpal and Harshit Jetley, Vehicle Emission Control Using Algae, *Journal of Basic and Applied Engineering Research* Print ISSN: 2350-0077; Online ISSN: 2350-0255; Volume 1, Number 3; October, 2014 pp. 91-92
- [17] Eiichi Ono and Joel L. Cuello, Selection of optimal microalgae species for CO₂ sequestration